

HIDEX



Hidex 300 SL and 600 SL

Liquid Scintillation Counters

www.lablogic.com

 **LabLogic**
EXPERIENCE & EXPERTISE

The most advanced transportable and user friendly LSC on the market

The Hidex 300 SL is a revolutionary instrument which incorporates the most advanced technology available, triple-to-double coincidence ratio (TDCR) counting.



Compact and transportable

The 300 SL has a modern and compact design measuring half the size and weight of some of its long standing rivals. It is therefore much easier to fit into smaller, more space conscious laboratories, such as transporting in research vessels or mobile labs.

User friendly software

The 300 SL uses an external Windows 10 PC, enabling several users to transfer their method and data files to other offline or networked PC's.

The MikroWin 300 SL software features an easy-to-use graphical interface and advanced data reduction capabilities. An unlimited number of protocols, easy export to Excel™, custom calculations and quench curves are all included.

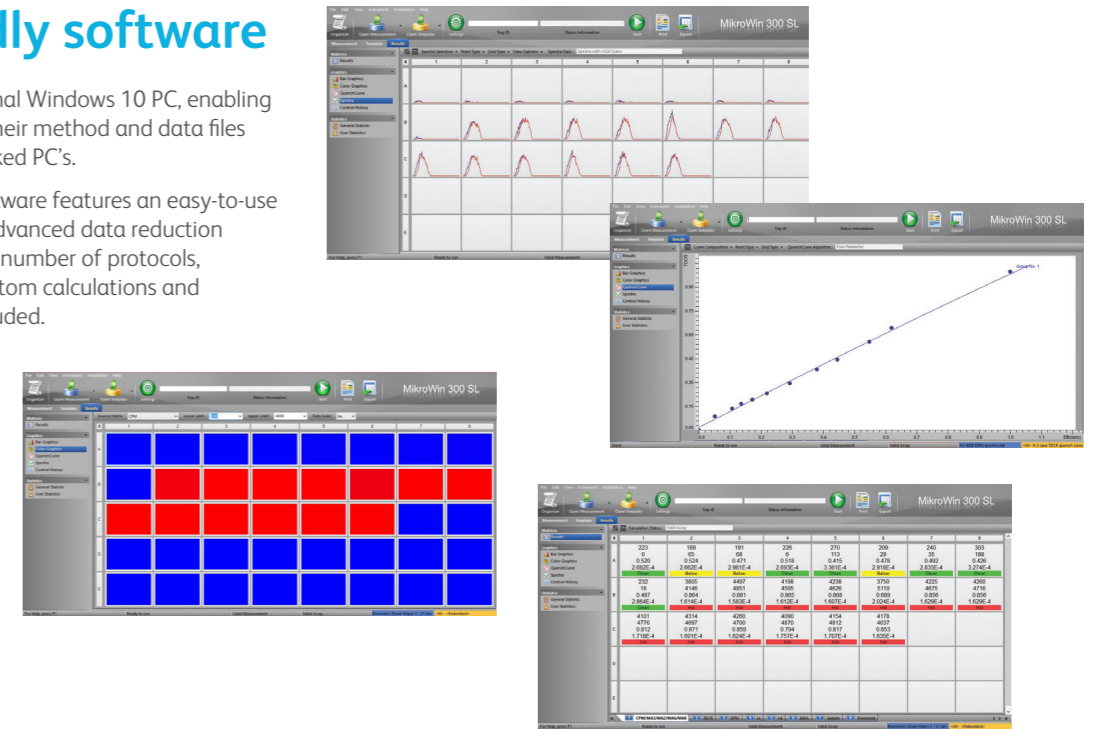

Integration with Laura software

The Hidex 300 SL can also be linked to Laura, the industry-standard radiochromatography software, which provides all the tools to enable the counter to be used in a 21 CFR part 11 compliant manner.

A major benefit is that time-stamped audit trails are generated automatically and cannot be modified, making it easier to track end-user activity.

Also in line with the data integrity guidelines, each end-user will have their own unique, secure ID login and password. Different levels of access can also be granted to specific end users.

Database data storage option

Allows database only storage of precious data. Laura supports both Oracle and MSSQL, with the data only accessible through Laura.

Multi-level security

Definable levels of access are controlled for each user.

Project level access

User access can be defined on a project basis.

Configurable audit trail

A comprehensive audit trail provides full accountability for data and user actions.

Electronic signatures

Configurable e-signatures are available, including dual signatures if required.

Lock projects, methods, evaluations against editing

Areas can be secured against editing using the user's login information.



TDCR technology

The 300 SL and 600 SL utilise a unique design with three photomultiplier detectors aligned 120 degrees from each other, which offers superior efficiency and counting results for both advanced research and environmental work.

In addition, both the 300 SL and 600 SL models can be used in triple coincidence mode only, which removes interference from chemiluminescence and the need to dark adapt. The counters can also be operated in dual coincidence mode using conventional standards and quench correction methods.

Quench curves can be generated and stored within the MikroWin software, which can be automatically applied or manually fitted to recalculate previous data.

No internal or external standard source

The TDCR method allows easy determination of sample counting efficiency without the use of any internal or external standard source of radioactivity, offering many benefits for the modern lab including no hidden disposal costs, no health hazard when servicing, and no transportation restrictions.

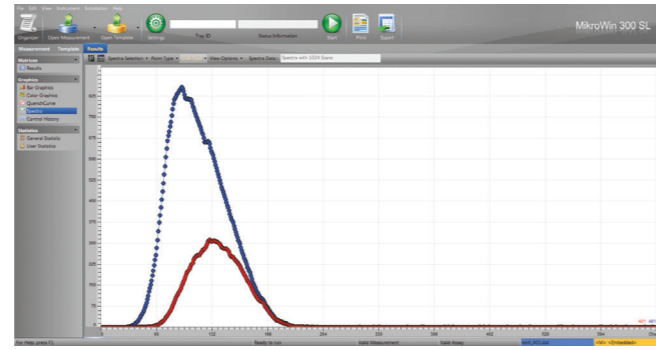

Advanced spectrum analysis highlighting triple and double count spectrums for each sample.

Optimal Lead Shield Design

A minimum of 70 mm lead in all directions provides excellent shielding and minimises instrument weight.

Copper Shielding

Eliminates X-rays from lead shield.

Measurement Chamber

Highly reflective proprietary paint maximises photon detection.

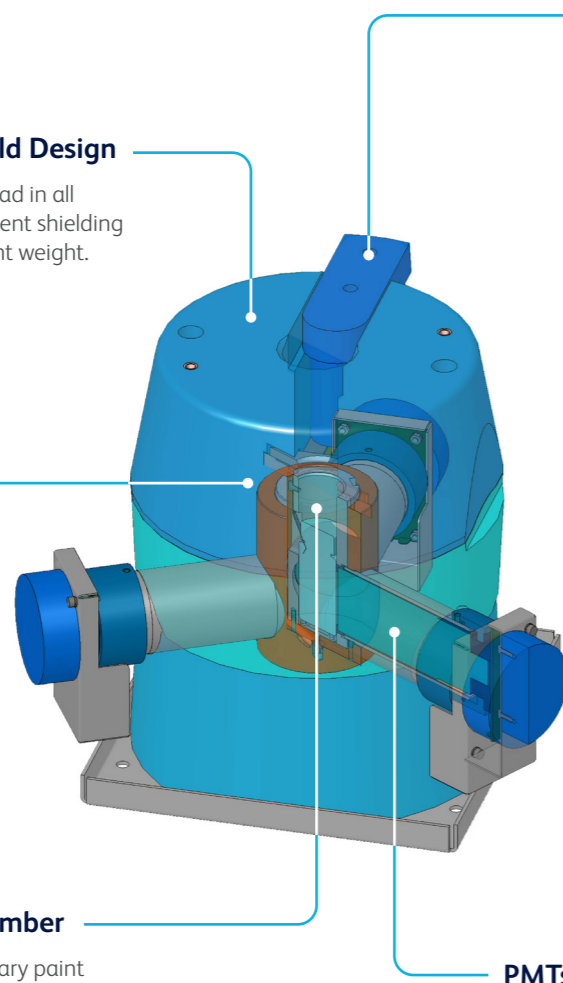

Lead Shutter

Reduces cosmic radiation.

Robotic Loading Arm

Removes the need for a complex elevator mechanism, preventing jams, and is easily serviceable.

No Source Required

Eliminating hazards and cost without compromising results.

PMTs

Three PMTs detectors in coincidence mode provide optimal counting geometry and facilitate TDCR calculations.

Super Low-Level Model

Similar to the standard instrument the Hidex 300 SL super low-level scintillation counter is equipped with additional lead shielding, low-level PMT detectors, and an active guard detector for further background reduction.

Ideal for ³H in water measurements, other low-level environmental monitoring, radiocarbon dating and biofuel verification.

Active Guard

The Active Guard is a separate scintillator detector which measures and subtracts real-time background radiation. The guard can be turned off for high energy samples and does not interfere with alpha/beta separation.

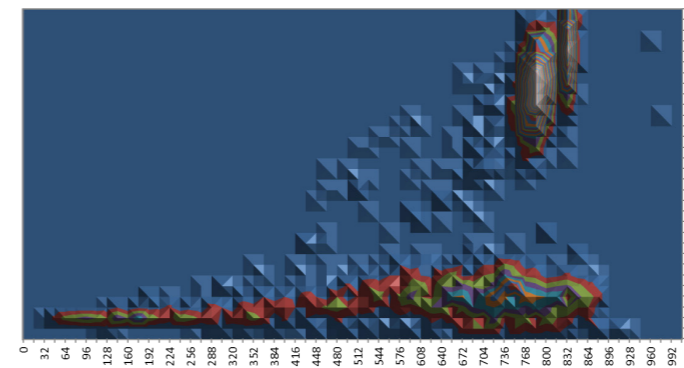

2D/3D spectral separation of alpha's from beta's based on pulse length discrimination.

300 SL Options

- Alpha/Beta Separation Module
- Temperature Control Module
- Low-Level PMT Detectors
- Digital Lead Shield
- External ¹⁵²Eu Standard

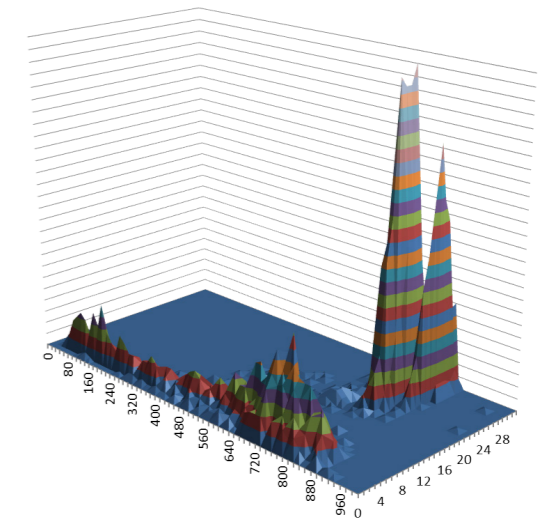

Specifications

Size 63 (L) x 52 (W) x 68.5 (H) cm

Weight Standard Model: 130 kg
Super Low Level Model: 180 kg

Sample Capacity 40/96
(20 mL/7 mL)

Electrical Connections 100 - 240 V 50 - 60 Hz

Energy Range β's 0 - 2,000 keV

Energy Range α's 0 - 10,000 keV

Efficiency ³H unquenched > 70%
³H (8 mL water, 12 mL cocktail) > 30% quenched
¹⁴C unquenched > 96%
α's (²¹⁰Po, ²³⁴U/²³⁸U, ²⁴¹Am, ²²²Rn, ²²⁶Ra) >95%

Please refer to the Technical Specification Sheet for further information

The ideal solution for the larger laboratory

Designed to meet the needs of laboratories processing large quantities of samples, the Hidex 600 SL is a high throughput automatic TDCR liquid scintillation counter.



Proven technology

The Hidex 600 SL uses the robust and unique triple-to-double coincidence ratio (TDCR) counting technology from the successful 300 SL series. Coupled with added sample capacity for up to 500 small vials (or 210 large vials), the 600 SL can process samples at a rate which will satisfy even the most demanding laboratories.

The instrument's software allows the user to work with an unlimited number of method files. Methods are barcode identified for automatic processing. Data files can be automatically exported in Excel®, csv or text for integration into LIM systems.



Super Low-Level Model

Similar to the standard instrument the Hidex 600 SL super low-level scintillation counter is equipped with additional lead shielding, low-level PMT detectors, and an active guard detector for further background reduction.

Ideal for ³H in water measurements, other low-level environmental monitoring, radiocarbon dating and biofuel verification.

Active Guard

The Active Guard is a separate scintillator detector which measures and subtracts real-time background radiation. The guard can be turned off for high energy samples and does not interfere with alpha/beta separation.

600 SL Options

- Alpha/Beta Separation Module
- Temperature Control Module
- Low-Level PMT Detectors
- Digital Lead Shield
- External ¹⁵²Eu Standard

Integration with Laura software

The Hidex 600 SL can also be linked to Laura, the industry-standard radiochromatography software, which provides all the tools to enable the counter to be used in a 21 CFR part 11 compliant manner.

A major benefit is that time-stamped audit trails are generated automatically and cannot be modified, making it easier to track end-user activity.

Also in line with the data integrity guidelines, each end-user will have their own unique, secure ID login and password. Different levels of access can also be granted to specific end users.

Database data storage option

Allows database only storage of precious data. Laura supports both Oracle and MSSQL, with the data only accessible through Laura.

Multi-level security

Definable levels of access are controlled for each user.

Project level access

User access can be defined on a project basis.

Configurable audit trail

A comprehensive audit trail provides full accountability for data and user actions.



Electronic signatures

Configurable e-signatures are available, including dual signatures if required.

Lock projects, methods, evaluations against editing

Areas can be secured against editing using the user's login information.

Specifications

Size	125 (L) x 69 (W) x 64 (H) cm
Weight	Standard Model: 200 kg Super Low Level Model: 350 kg
Sample Capacity (20 mL/7 mL)	210/500
Electrical Connections	100 - 240 V 50 - 60 Hz
Energy Range β's	0 - 2,000 keV
Energy Range α's	0 - 10,000 keV
Efficiency	³ H unquenched > 70% ³ H (8 mL water, 12 mL cocktail) > 30% quenched ¹⁴ C unquenched > 96% α's (²¹⁰ Po, ²³⁴ U/ ²³⁸ U, ²⁴¹ Am, ²²² Rn, ²²⁶ Ra) > 95%

Please refer to the Technical Specification Sheet for further information

Service and Support

Users of our systems can benefit from our comprehensive, fully inclusive service and support.

We can give reassurance that if things go wrong or you need expert advice, help is only an e-mail or phone call away.

Validation Services

Our Validation Service enables you to implement and get maximum value from your investments as soon as possible.

We work as a partner with your Quality Manager, System Manager and users to provide a tailored Validation Plan, suited to your needs. Our Validation Specialists have years of experience in GLP system validation, detailed knowledge of our systems, together with other industry standard systems to help you meet company and regulatory requirements.

Training

LabLogic can provide a variety of training courses and workshops to help you get the most out of your instrument and software.

All training is performed by our expert Product and Support Specialists who have many years experience in the development and use of the instruments and software.

Certificates can be provided to complement your internal GLP training records.

Europe & Worldwide

LabLogic Systems Limited

Paradigm House, 3 Melbourne Avenue
Broomhill, Sheffield, S10 2QJ, UK

E-mail: solutions@lablogic.com

Tel: +44 (0)114 266 7267

Fax: +44 (0)114 266 3944

www.lablogic.com



INVESTORS
IN PEOPLE | Silver
Until 2022

USA & Canada

LabLogic Systems, Inc.

1911 N US HWY 301, Suite 140
Tampa, FL 33619, USA

E-mail: solutions@lablogic.com

Tel: +1-813-626-6848

Fax: +1-813-620-3708

www.lablogic.com



LabLogic

EXPERIENCE & EXPERTISE